

ELECTRONIC CONTROL ACTUATOR

“ **Nucom Series** “

LINEAR TYPE

Nucom – L25

Nucom – L50

OPERATION MANUAL

Koei Industry Co., Ltd.

FOR YOUR SAFETY

In order for better and safety use of the product for a long period, please observe this “WARNING and CAUTION” carefully.

Here are the specification and operation manual for the product to prevent suffering injury or loss by accidents.

The contents are divided into “WARNING” and “CAUTION” for different degree of risks.

Please strictly observe them, as both of them are very important for your safety.

 **WARNING:** Improper handling of the product disregarding the notes under this mark may cause injury or death to a man.

 **CAUTION:** Improper handling of the product disregarding the notes under this mark may cause injury or material loss.



WARNING

- * This product is not of explosion-proof.
Do not use it in the environment with flammable gas (gasoline etc.) or corrosive gas.
- * Do not dismantle the actuator from the valve during power operation.
- * Do not make wiring work when power is being supplied.



CAUTION

- * Do not drop the product or give a shock to the product, for it may cause defects to the product.
- * Do not get on the actuator, or it may cause defects or an accident.
- * Do not make wiring work in the rain or in splashing water.



CONTENTS



1. GENERAL
2. EXTERNAL DRAWINGS
 - 2-1 Configuration and names of parts
 - 2-2 External drawings Nucom-L25, L50
3. FUNCTIONAL SPECIFICATION
4. STRUCTURE
 - 4-1 Operation principle
5. INSTALLATION
 - 5-1 Installation place
 - 5-2 Ambient temperature, fluid temperature
6. ASSEMBLY WITH A VALVE
7. WIRING
 - 7-1 Wiring with power / input signal
 - 7-2 Wiring work
8. RATED POWER / INPUT SIGNAL AND WIRING DIAGRAM
 - 8-1 Rated power
 - 8-2 Input signal
 - 8-3 Recommendable fuse or breaker
 - 8-4 Wiring diagram
9. CONTROL PACK
 - 9-1 Names of parts
 - 9-2 Mode selection
 - 9-3 Sensitivity volume and ZERO / SPAN adjustment
10. ADJUSTMENT
 - 10-1 Adjustment of upper limit position
 - 10-2 Adjustment of torque limiters
 - 10-3 Adjustment of top / bottom no-voltage contact output (Option)
 - 10-4 Adjustment of potentiometer
11. OPERATION
 - 11-1 Manual operation
 - 11-2 Power operation
12. MAINTENANCE / INSPECTION
13. TROUBLE SHOOTING

1. GENERAL

The system is a linear type Electronic Actuator to position valve opening in continuous operation with direct signals (4 ~ 20mA) from a controller or computer.

The system is robust, maintenance free and far more precise (Resolution 1/250) than conventional pneumatic actuators, and will help save process equipment and running costs in a great extent.

⊗ FEATURES

- * Compact and light
- * High resolution (More than 1/250)
- * Direct / reverse action selectable by mode selection switch
- * An action during power interruption selectable by mode selection switch
- * Perfectly resin-molded servo control pack is designed to drip and vibration proof
- * Helps simplify process flow
- * Saves process equipment and running costs to one over decades
- * Torque limiter and thermal protector fitted to prevent motor-burnout
- * Crank handle provided for manual operation (power should be off)

2. EXTERNAL DRAWINGS

2-1 Configuration and names of parts

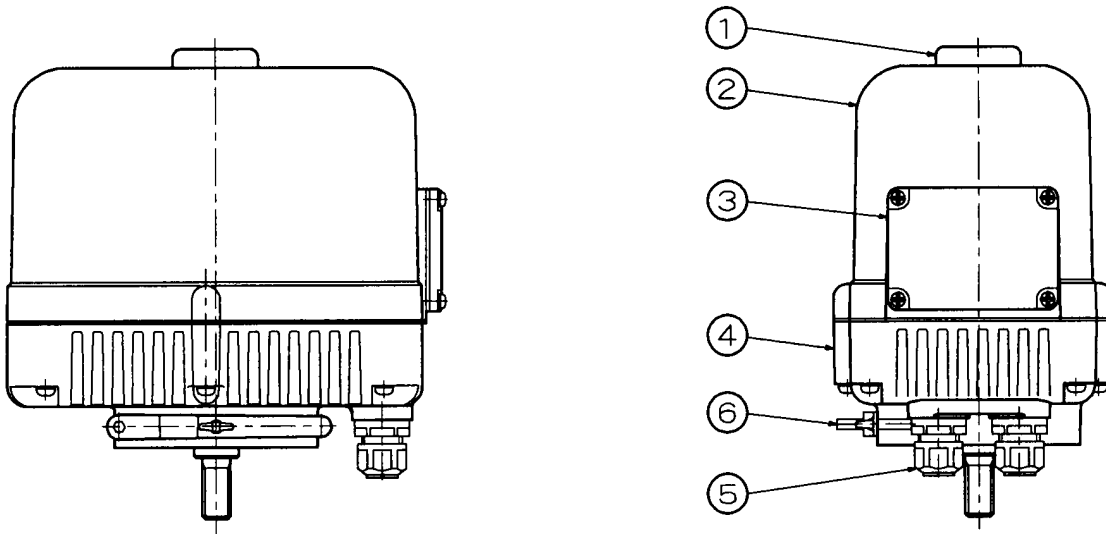

- FIG. 1 -

| No. | NAME OF PART |
|-----|----------------------------|
| 1 | RUBBER CAP FOR MANUAL HOLE |
| 2 | BODY COVER |
| 3 | CONDUIT COVER |
| 4 | BODY BASE |
| 5 | CONNECTOR |
| 6 | MANUAL HANDLE |

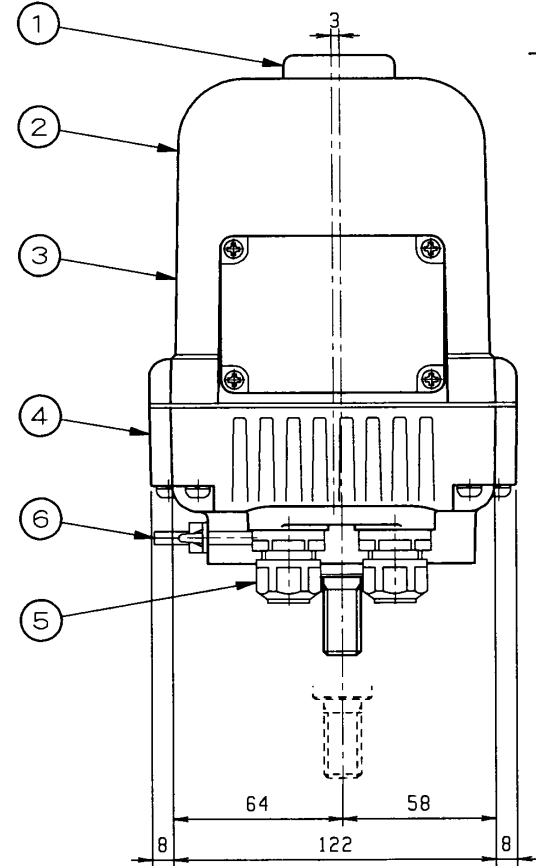
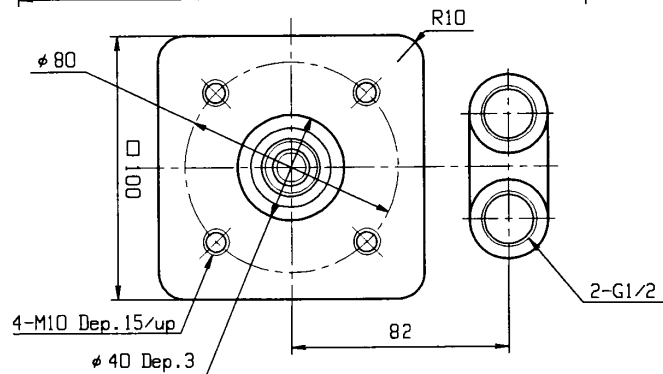
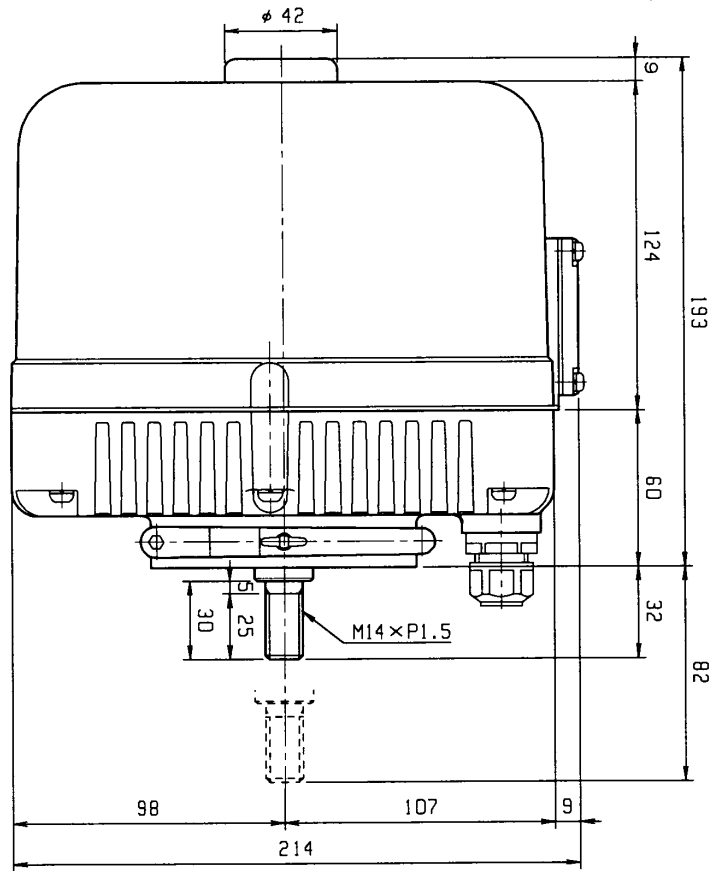

(2) - 2
- FIG. 2-

Model : Nucom- L25, L50

| No. | NAME OF PART | MATERIAL |
|-----|----------------------------|----------|
| 1 | RUBBER CAP FOR MANUAL HOLE | NBR |
| 2 | BODY COVER | ADC12 |
| 3 | CONDUIT COVER | ADC12 |
| 4 | BODY BASE | ADC12 |
| 5 | CONNECTOR | NYLON 66 |
| 6 | MANUAL HANDLE | SCS13 |

3. FUNCTIONAL SPECIFICATION

| ITEM \ MODEL | Nucom-L25 | Nucom-L50 | |
|------------------------|--|--|------|
| RATED POWER | AC100V±10% (50/60 Hz) AC115V±10% (50/60 Hz) AC200V±10% (50/60 Hz) AC230V±10% (50/60 Hz) | AC110V±10% (50/60 Hz) AC120V±10% (50/60 Hz) AC220V±10% (50/60 Hz) AC240V±10% (50/60 Hz) | |
| INPUT SIGNAL | 4~20mA·DC 4~12/12~20mA·DC | (Standard Specification) (Optional Specification) | |
| SHAFT OUTPUT | 1961N(200kgf) | 4903N(500kgf) | |
| OPERATION SPEED | 1.4 mm/sec (50 Hz) | 1.7 mm/sec (60 Hz) | |
| SHAFT STROKE | 0~25mm | 0~50mm | |
| RESOLUTION | Over 1/250 | | |
| DEAD ZONE | Max. 0.5% F.S. | | |
| LINEARITY | Max. 0.5% F.S. | | |
| ACTION MODE | Direct or reverse action selectable | | |
| MODE WHEN SIGNAL "OFF" | CLOSE/STOP/OPEN: selectable | | |
| PROTECTION SYSTEM | * Upper limit switch (Standard spec.) * Bottom torque limiter (Standard spec.) * Motor thermal protector (120°C) | | |
| AMBIENT TEMPERATURE | Ambient temperature within : -25~55°C | | |
| RATED CURRENT | AC100V | 0.6A | 0.7A |
| | AC110V | 0.7A | 0.8A |
| | AC115V | 0.6A | 0.7A |
| | AC120V | 0.7A | 0.8A |
| | AC200V | 0.3A | 0.4A |
| | AC220V | 0.4A | 0.5A |
| | AC230V | 0.3A | 0.4A |
| | AC240V | 0.4A | 0.5A |
| MOTOR | 20W Reversible motor | | |
| INSULATION GRADE | E Class | | |
| RATED OPERATION TIME | Continuous | | |
| POSITION DETECTOR | Potentiometer(Backlash revision type) | | |
| OUTPUT SIGNAL | *4~20mA· DC(Standard spec. Maximum load resistance 500Ω) *Top/Bottom limit voltage output (Optional extra) | | |
| INSULATION RESISTANCE | Between power terminal --- case : 500V DC/100MΩ | | |
| WITHSTAND VOLTAGE | Between power terminal --- case :1500V AC/1 minute | | |
| SERVO CONTROL UNITS | Resin molded semi-conductors | | |
| MANUAL OPERATION | Detachable crank handle (Standard accessory) | | |
| WIRE INLET | G1/2 × 2 (Water-sealed conduit) | | |
| ENCLOSURE PROTECTION | NEMA-4X (IP-66) | | |
| EXPLOSION PROOF | Non explosion-proof | | |
| MOUNTING ANGLE | From vertical to horizontal angles | | |
| BODY MATERIAL | Diecast Aluminum | | |
| COATING | Melamine baking coating (silver) | | |
| WEIGHT | 6.9 kg | | |

4. STRUCTURE

4-1 Operation principle

Control pack (Electronic module) makes relational operation between input signals (4~20mA) and position signals detected by potentiometer, and drives motor in direction to balance both the signals. Motor stops at the position where both the signals are balanced. Motor rotation (Direct and reverse) is transmitted in the order of

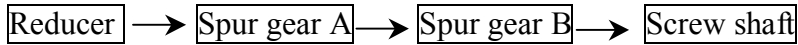

then converted into linear movement to stroke main shaft up and down.

Potentiometer always detects the shaft movement and feedbacks it to control pack.

The sequence of the above movement allows the system to continuously perform proportional operation against input signals.

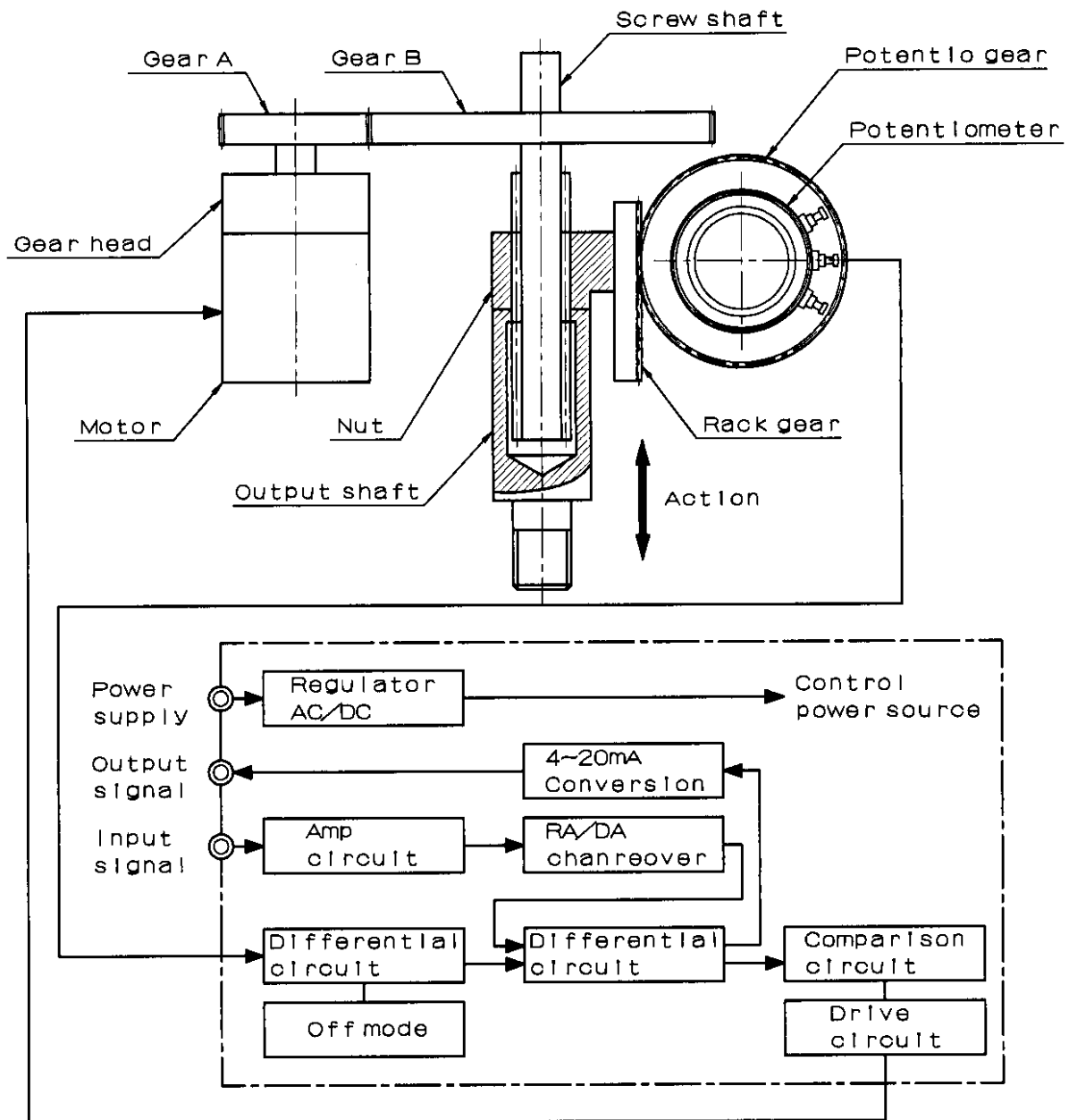

CAUTION ON ENVIRONMENTAL INSTALLATION CONDITIONS

5.INSTALLATION

5.1 Installation place

Caution on indoor installation

- * The actuators are not of explosion-proof type. Avoid to install in a hazardous place.
- * In case of installation in a place where water or materials are always splashing, it is necessary to cover whole the unit.
- * It is recommendable to reserve a space for manual maintenance work.
(depends on installation conditions)

Caution on outdoor installation

- * To avoid rainwater or direct sunlight, it is necessary to cover or shade whole the unit.
(This concerns temperature rise in the unit, and anti-climate property of seals used.)
- * It is recommendable to reserve a space for manual maintenance work.
(depends on installation conditions)

Actuator surface materials and treatment

| MODEL PART | Nucom-L25 | Nucom-L50 |
|-------------------------|---|-----------|
| BODY BASE | Die cast Aluminum Oxidation treatment Melamine baking coating | |
| BODY COVER | Die cast Aluminum Oxidation treatment Melamine baking coating | |
| SIDE PLATE COVER | Die cast Aluminum Oxidation treatment Melamine baking coating | |
| OUTPUT SHAFT | SUS 304 | |
| MANUAL DRIVEHOLE CAP | NBR | |
| OIL SEAL | NBR | |

5-2 Ambient temperature / fluid temperature

Ambient temperature

- * Environmental temperature range for use : -25°C~55°C.
- * For use in minus temperature, space-heater is available at option.
- * For use in temperature beyond the specified range, refer to our Sales Dept.

Fluid temperature

It is occasional that if the actuators are applied to high temperature fluid lines, the unit may be overheated by transmission of the line heat. In such a case, use radiation type yoke and couplings.
(available at option)

- * Standard yoke and couplings : For fluid temperature below 65°C
- * Radiation type yoke and couplings : For fluid temperature over 65°C

⚠ CAUTION ON ASSEMBLY WITH A VALVE

6. ASSEMBLY WITH A VALVE

⊗ Names of parts

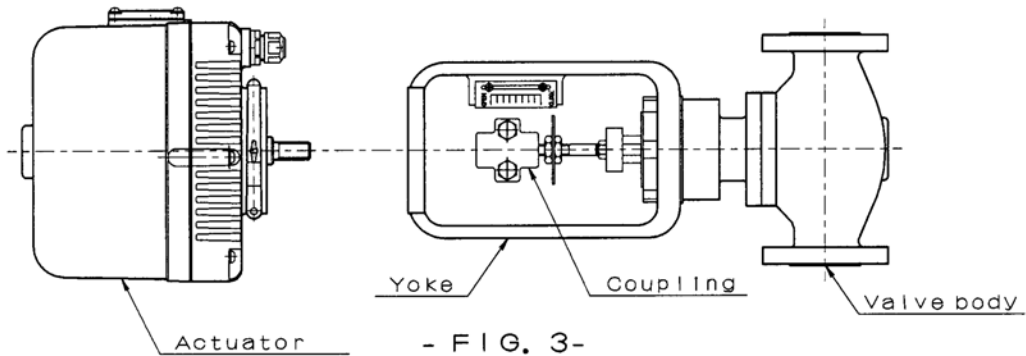

As shown in Fig.3, the actuator and a valve are individually structured for easy disengagement when trouble is occurred.

⊗ Assembly procedure

1. Be sure that power is off before making manual operation.
2. Drive the valve manually and confirm that it is normal.
Then set it at full close position.
3. Fit a yoke to the actuator.
4. After the actuator is set at full close, engage output shaft and the valve stem with coupling.
5. Manually drive the actuator, and make sure that it moves smoothly without eccentricity.

⚠ CAUTION ON WIRING WORK

7. WIRING

7-1 Wiring of power and signal cables

Remove the side plate cover (or body cover), and find 6-P terminal block thereunder.

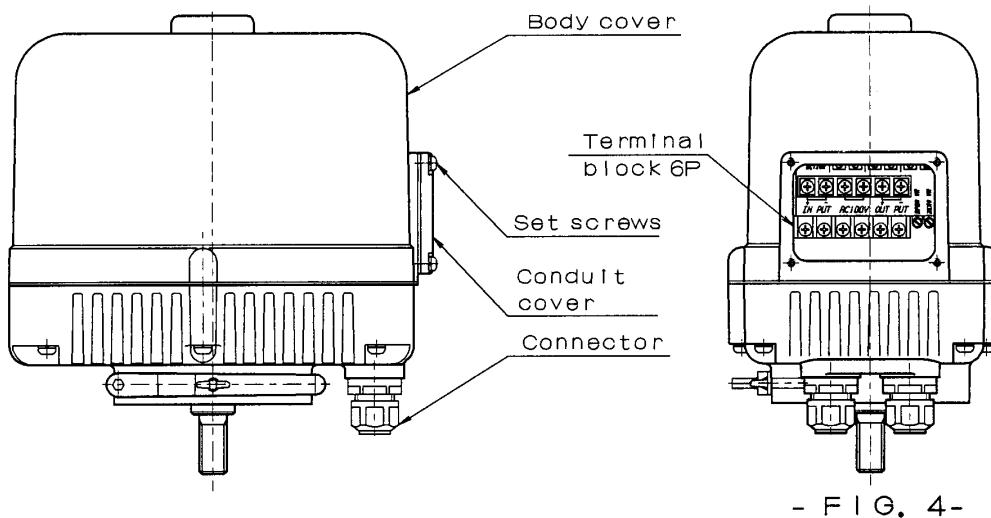

⌘ Caution on wiring

A qualified person based on electric equipment technical standard should make wiring work. Refrain from wiring work under rainy or high humid conditions.

Make proper wiring to the wiring diagram.

For all connections use fork crimped-on terminals.

For the standard resin conduit, use a cable of outer diameter $\phi 9\sim\phi 11$. (Refer to Fig.5)

For customer conduit, select a proper size cable to match it to avoid water ingress through the gap.

Secure the cover and conduit tightly after power/signal wiring is over to avoid water ingress.

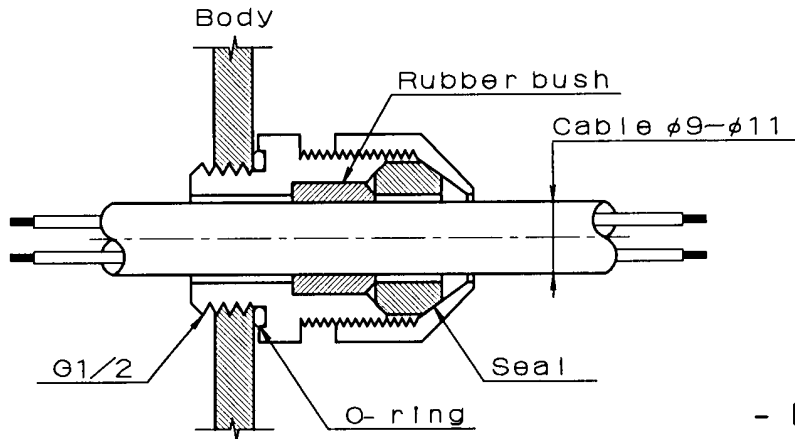

- FIG. 5-

7-2 Wiring work

Use sufficiently sealed tubes or conduit to prevent water ingress.

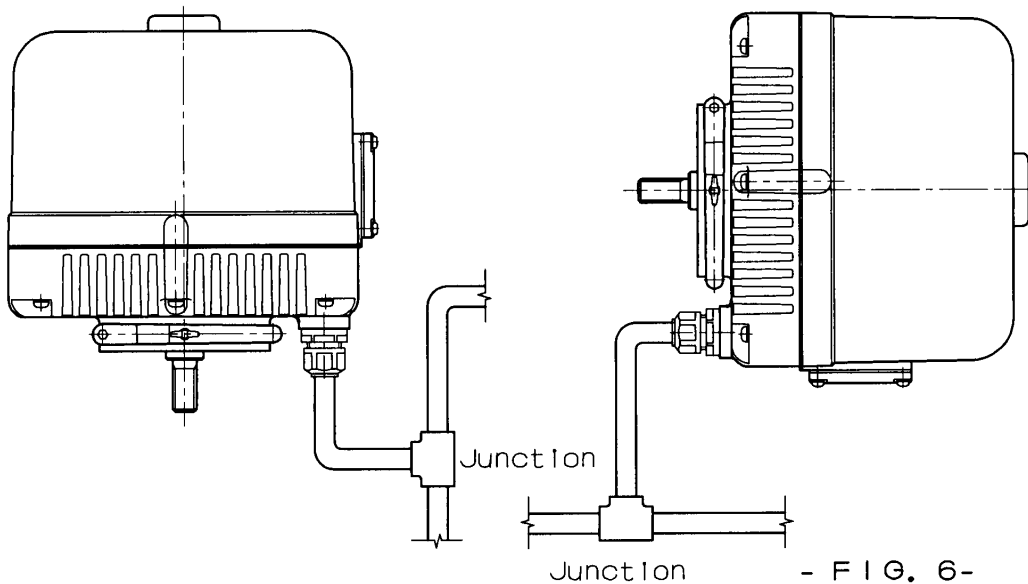

- FIG. 6-



CAUTION ON USE

8. RATED POWER / INPUT SIGNAL AND WIRING DIAGRAM

8-1 Rated power

| |
|-------------------------------------|
| AC 100/110/115/120V ± 10% (50/60Hz) |
| AC 200/220/230/240V ± 10% (50/60Hz) |

For different supply from the above, refer to our Sales Dept.

8-2 Input signal

| | |
|---------------------|----------|
| 4~20mA DC (1~5V DC) | Standard |
| 4~12mA DC | Option |
| 12~20mA DC | Option |

Note: Wiring should be made properly to reject noise disturbance etc.

8-3 Recommendable fuse or breaker

Install a protection fuse or breaker on supply source according to the following table

| Model | Capacity of fuse / breaker | Motor capacity |
|-----------|----------------------------|----------------|
| Nucom-L25 | 5A | 20W |
| Nucom-L50 | 5A | 20W |

8.4 Wiring diagram

| | |
|--|------------------|
| Standard | CIR9612E (Fig.7) |
| With Top / Bottom no-voltage limit switches | CIR9612F (Fig.8) |

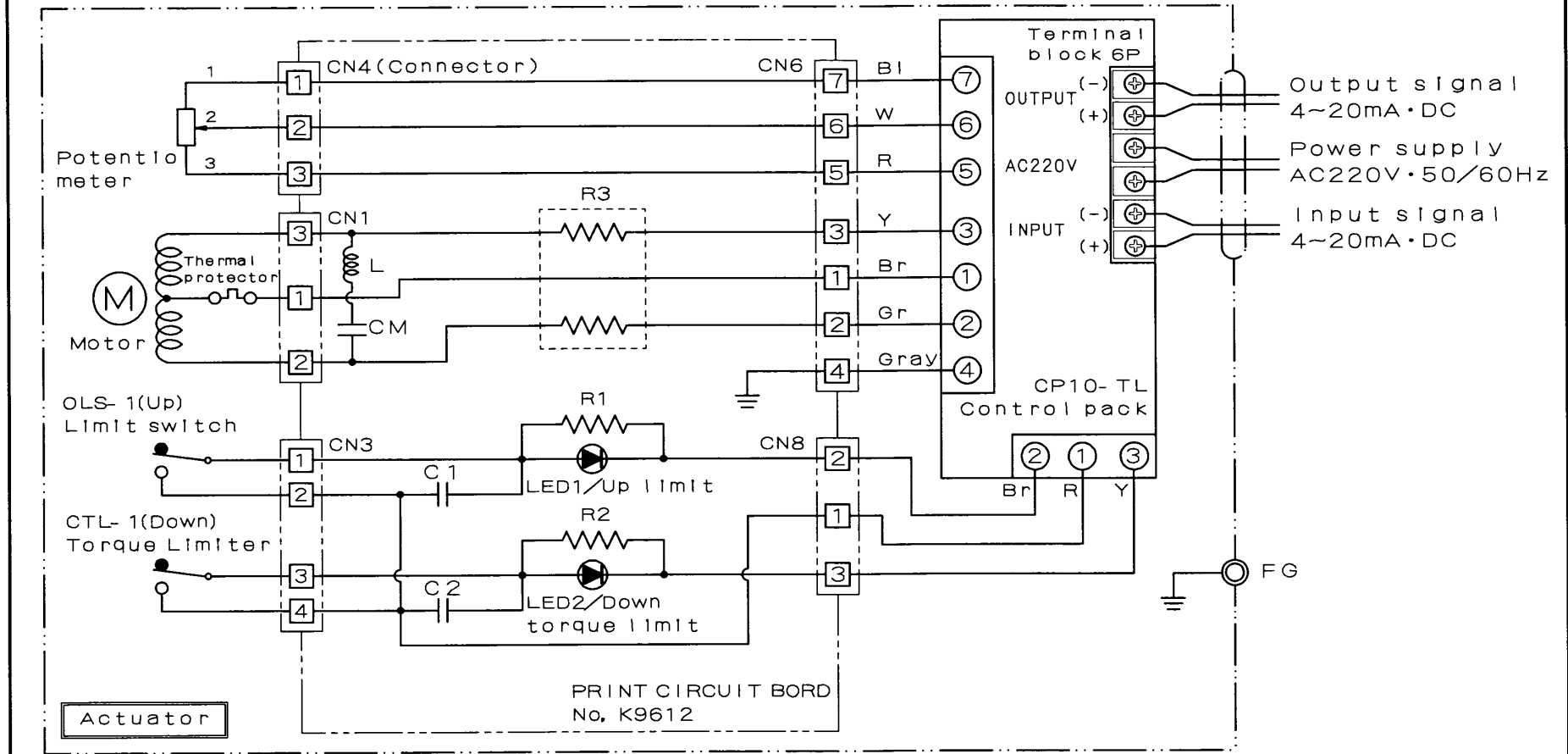

External circuit diagram

| | |
|----------------------------------|-----------------------|
| ELECTRIC ACTUATOR WIRING DIAGRAM | DRAWING No. CIR-9612E |
| MODEL: Nucom- L25, L50 | DATE: '1997, 01, 20 |
| KOEI INDUSTRY CO., LTD. | SPEC: STD |

(8) - 4
- FIG. 8-

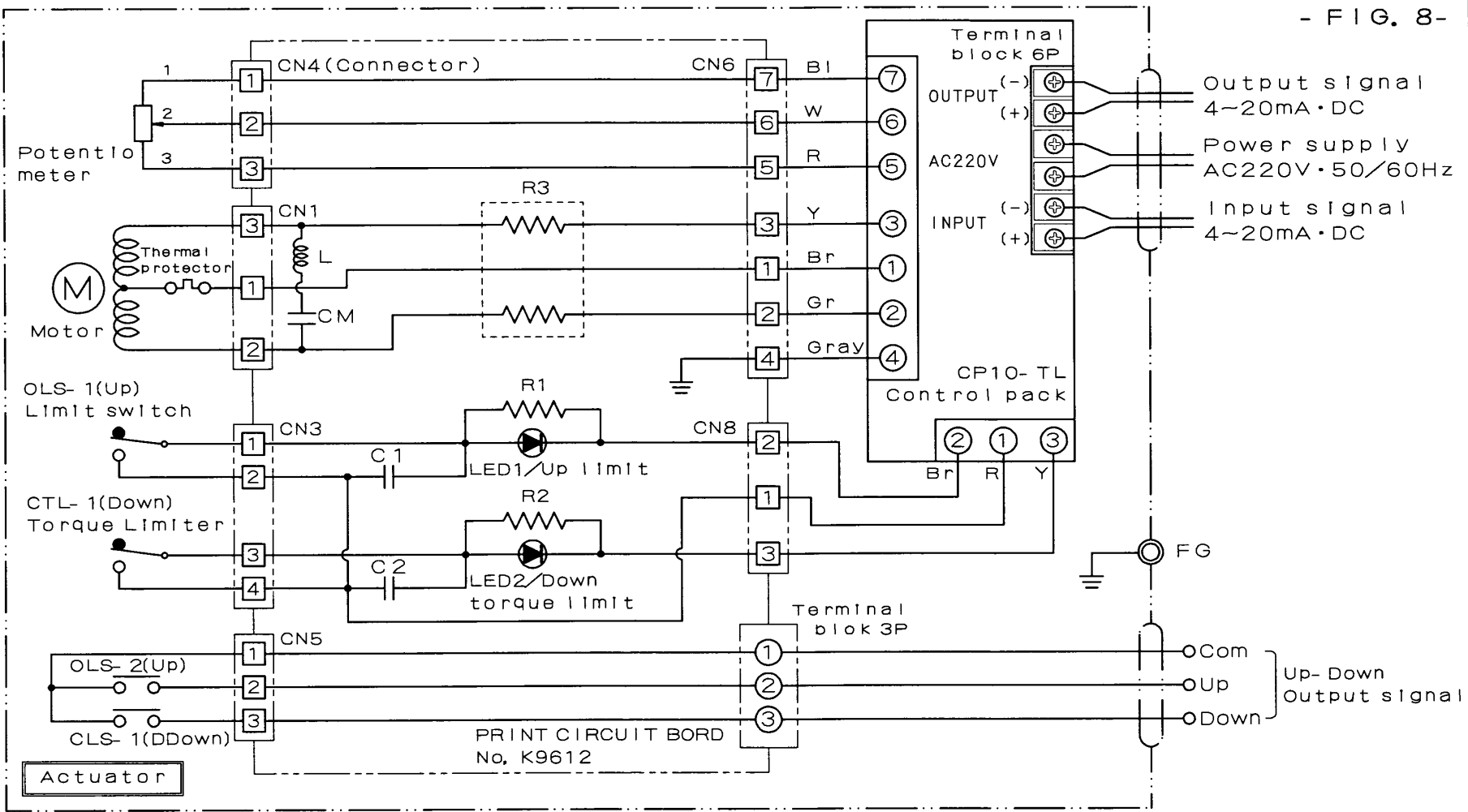

*No-voltage spare limit switch

External circuit diagram

| | |
|----------------------------------|-----------------------|
| ELECTRIC ACTUATOR WIRING DIAGRAM | DRAWING No. CIR-9612F |
| MODEL: Nucom- L25, L50 | DATE: '1997, 01, 20 |
| KOEI INDUSTRY CO., LTD. | SPEC: OPTION |



CAUTION ON USE

9. CONTROL PACK

9-1 Names of parts

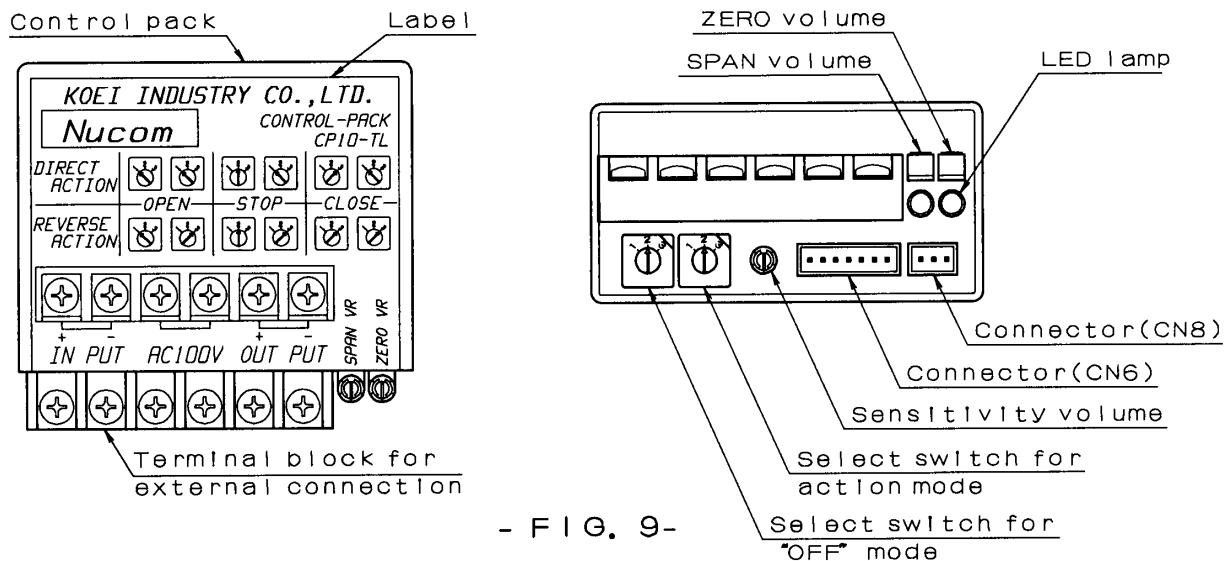

- FIG. 9 -

9-2 Mode selection

⊗ Input signal and operation direction

Direct or reverse action is selectable by Select switch.

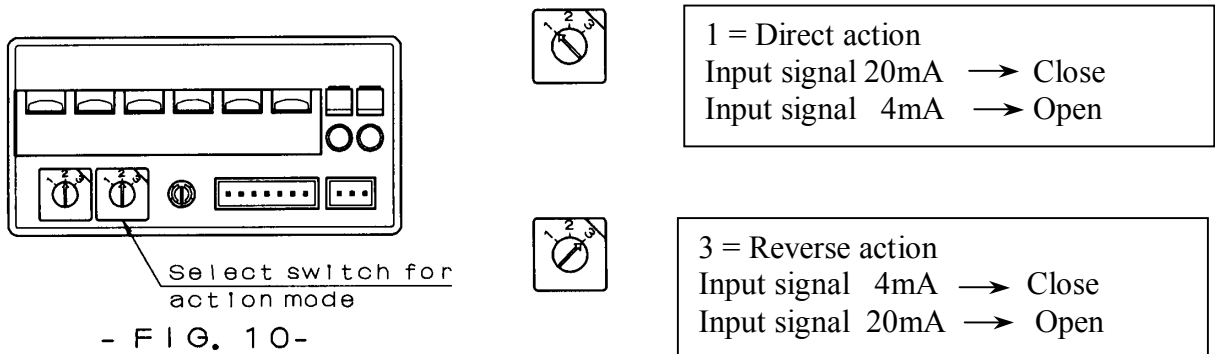

- FIG. 10 -

⊗ Action during signal interruption

When signal circuits are open or a signal is lowered below 2mA during operation, the system recognizes as "signal interrupted", and stops movement at the preset position by Select switch.

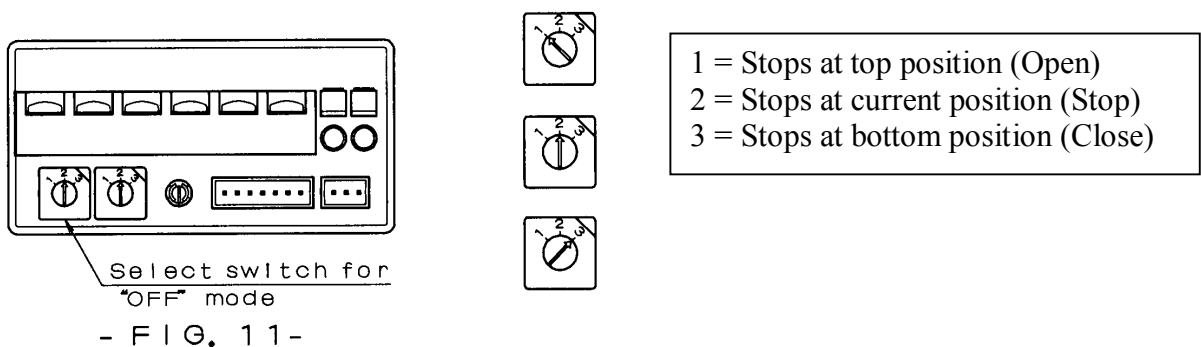

- FIG. 11 -

Note : Before setting a direction or action mode, be sure that power is off.

* Direct / reverse direction and action mode during signal interruption (signal “off”) may be set in the following 6 combinations.

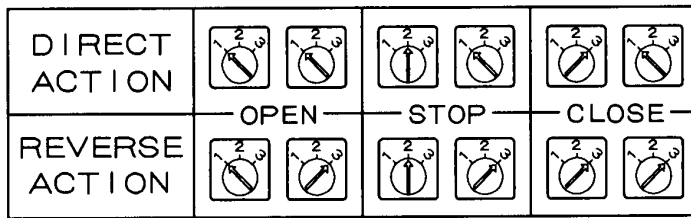

- FIG. 12-

* Unless expressly instructed, the unit is preset before shipment in combination of :

| | |
|---|-------|
| Reverse direction (RA) | Right |
| Stop mode in signal interruption (STOP) | Left |

Note : 4~20mA signals from a computer or controller should be accurately adjusted.

The unit recognizes any signals below 2mA as “signal interrupted” and will automatically operate accordingly.

9-3 Sensitivity volume and ZERO / SPAN adjustment

* Resolution is preset at 1/250 (0.4%) before shipment.

Noise disturbance on signals will unnecessarily and frequently drive the motor and will heavily shorten its life. In such a case, user may mitigate the influence of such disturbance by lowering sensitivity within an allowable range.

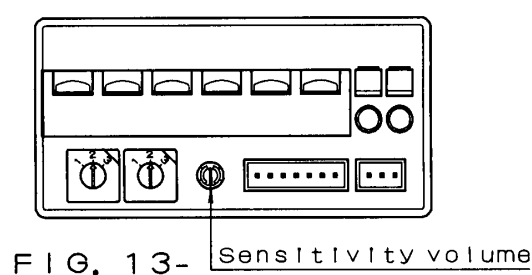

- ⊗ Sensitivity volume
 - * Clockwise for higher
 - * Counter clockwise for lower
 - * Max. resolution : About 1/400
 - * Min. resolution : About 1/100

- ⊗ Zero volume
 - * CW for higher
 - Adjustable range : -25 to +25%

- ⊗ Span volume
 - * CW for wider
 - Adjustable range : 50 to 200%

Note : First adjust Zero, then adjust Span.

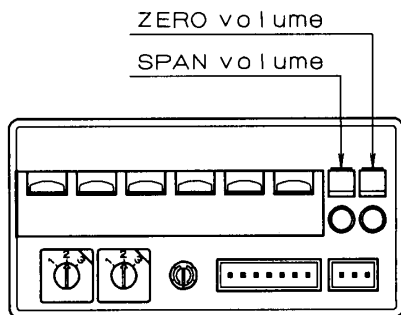



FIG. 14-

Note : ZERO / SPAN volume is pre-adjusted appropriately before shipment.

Do not re-adjust it unless it is really necessary.

For adjustment, use a trimmer driver within the torque range of 300g/cm.

Avoid applying excessively large force, for it may cause troubles to the unit.

 Confirm that power is OFF before making manual operation

10. ADJUSTMENT

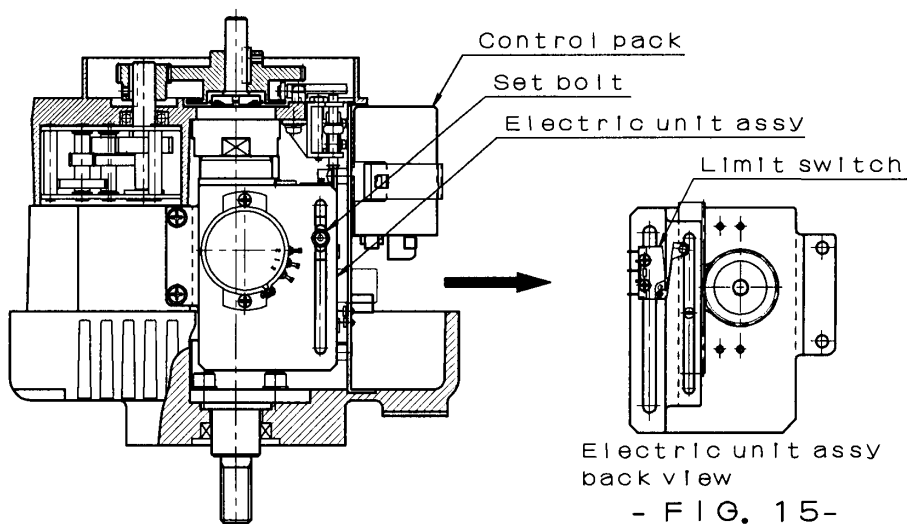

10-1 Adjustment of upper position limit

1. Remove body cover.
2. Loosen bolts (M3 hexagon socket bolts) to allow the switch sliding up and down.
3. Set the output shaft at upper limit position by manual handle, then slide the switch to the position where it clicks (becomes in function), and bolt it up.
4. After the setting is over, confirm by manual handle that the switch properly functions, also the lamp lights at the position.

Note : Confirm that power is off before making manual operation.

The unit with top / bottom torque limiters (for 3 way valve) is not fitted with upper position limit switch.

10-2 Adjustment of torque limiters

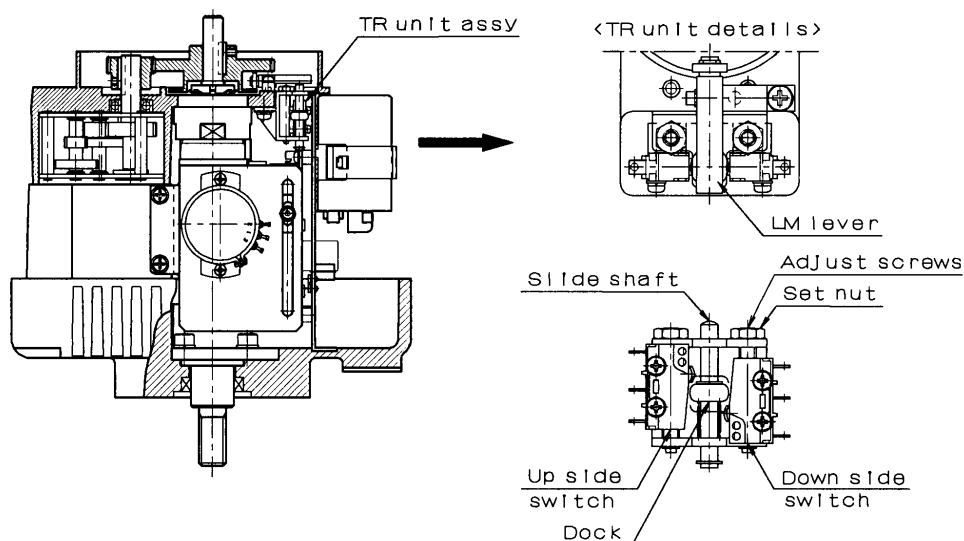

Note : Upper side switch is only fitted to the unit “with top / bottom torque limiters” (for 3 way valve).

 Confirm that power is OFF before making manual operation

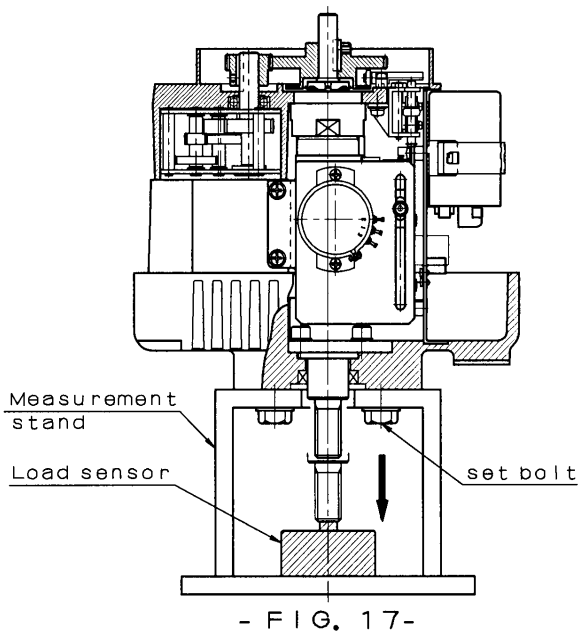

The torque limiter is preset at rated torque before shipment.
As shown in Fig.17, with an actuator bolted on the measurement stand, the load cell detects the torque as the limiter switch becomes in function.

Preset torque rate

| | |
|-----------|----------------|
| Nucom-L25 | 1961N (200kgf) |
| Nucom-L50 | 4903N (500kgf) |

Note : In principle, do not reset torque after shipment . Resetting without proper jigs may make it inexact and may cause trouble. Avoid power operation without load at the bottom position.

⊗ Resetting procedures with measurement jigs

1. Fix an actuator body on measurement jigs. (see Fig.17)
2. Supply up / down signals to the actuator.
3. Install a load cell (detector) so as that the output shaft will touch it at the bottom position.
4. Loosen TR unit fixing nut (M4). (see Fig.16)
5. Confirm that as the output shaft touches at the detector with downward signal, the limit switch becomes effective, the motor stops and the lamp lights.
Load current torque and compare it with desired rate to be reset.
6. Adjust screw is turnable with 2mm L-wrench, CW (Right turn) for smaller, CCW for larger torque.

Note : Adjust torque slowly from small side to larger side.
Avoid to fast turn the screw CCW (Left turn), or it may possibly set torque at an excessively large rate and may cause trouble.

< Allowable toque setting range >

| | |
|-----------|---------------------------|
| Nucom-L25 | 1471~2942N (150 ~ 300kgf) |
| Nucom-L50 | 3432~5394N (350 ~ 550kgf) |

7. After setting, secure the adjust screw with the nut. (see Fig.17)
When securing, support the wrench and nut with your fingers.
8. Repeat test 5 times to confirm the reproducibility of torque limiter's action, then paint fixing nut with lock paint.

 Confirm that power is OFF before making manual operation

10-3 Adjustment of top / bottom no-voltage contact output (OPTION)

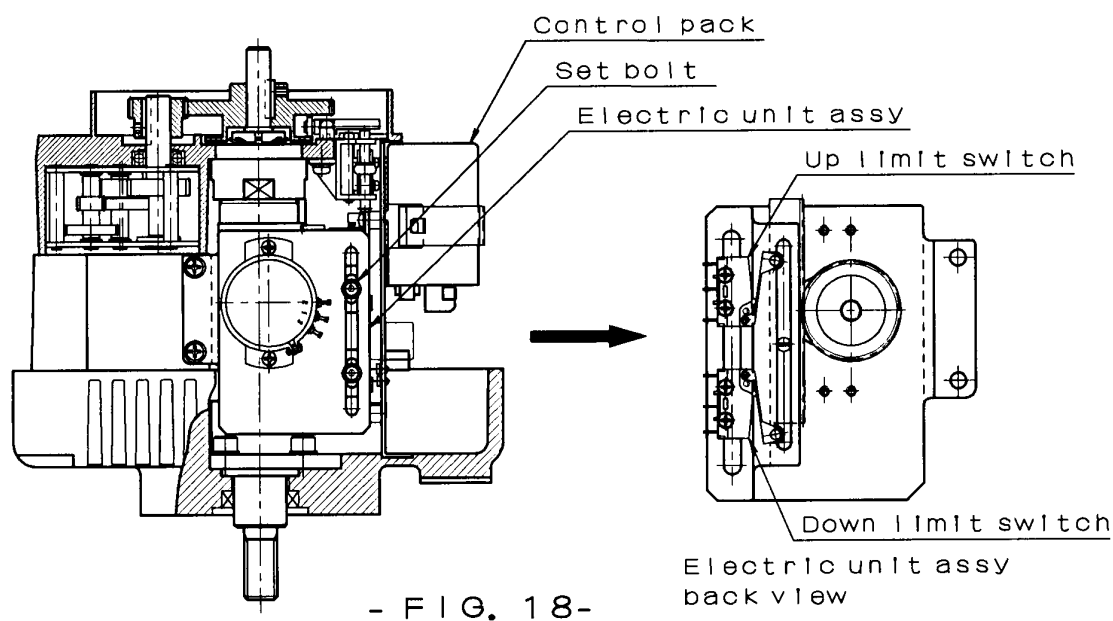

1. Remove the body cover. (see Fig.18)
2. Loosen top / bottom bolts (M3 hexagonal holed) to allow the switch sliding up and down.
3. Set the output shaft by manual handle at top / bottom positions, then slide the switch to the position where it clicks (becomes effective), then bolt it up.
4. After the setting is over, reconfirm by manual handle that the switch is effective at top / bottom positions.
5. Confirm by power operation that the switch is effective to output signals to individual terminals on the terminal block.

10-4 Adjustment of potentiometer

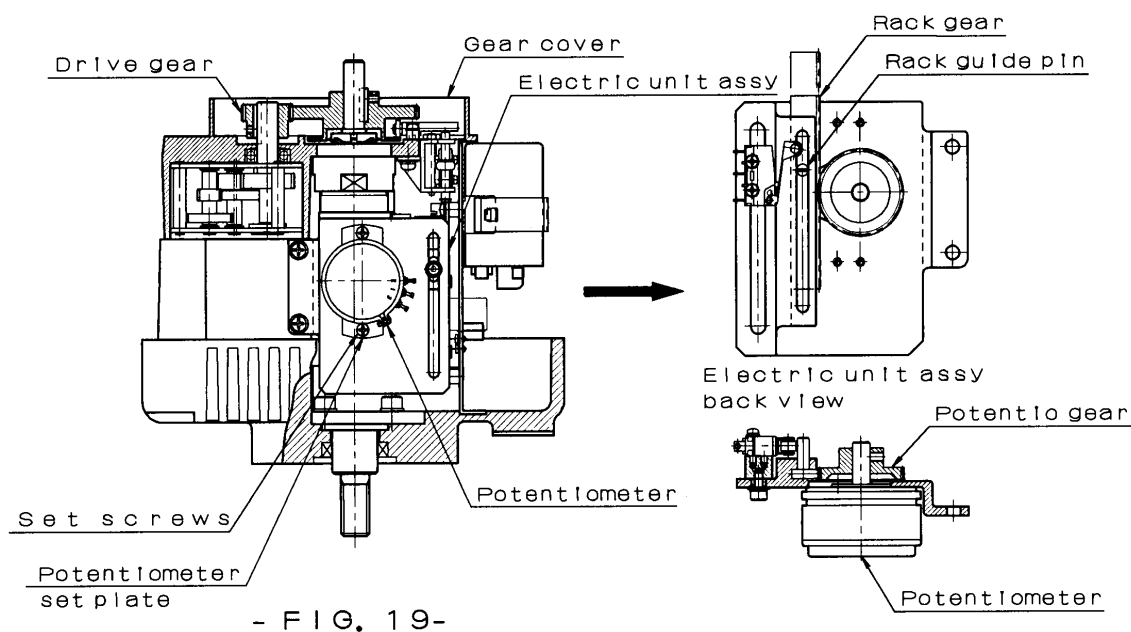

 Confirm that power is OFF before making manual operation

⊗ As the potentiometer has been preset and tested before shipment, readjustment is in principle not necessary unless it is faulty.

If the length of shaft stroke is changed, user may adjust ZERO / SPAN volume in the control pack to suit. If adjustment is required beyond ZERO / SPAN range, then adjust potentiometer in the following procedures. (see Fig.19)

1. Cut power and signal off.
2. Remove body cover.
3. Unscrew and remove gear cover and driving spur gear from reducer shaft.
4. With input signal 4mA (bottom), manually set output shaft at the bottom position.
5. Supply power and 4mA signal and reducer shaft will turn in either direction.
 Note : When input signal and output shaft position are exactly matched each other, the shaft will stop or will not turn.
 When supplying power and signals, confirm that the manual handle is removed off.
6. Loosen fixing screws to allow potentiometer to turn, then fix it at the position where reducer shaft stops, and fix the screw top with locking paint.
7. After the setting is over, firmly screw up spur gear and gear cover.
 Note : Confirm power is off during the work.
8. Confirm with power and signals that the positioning is exact to signal rate.
 Note : During power operation, a load should be connected with the bottom side, otherwise, positioning may become inexact.

11. OPERATION

11-1 Manual operation

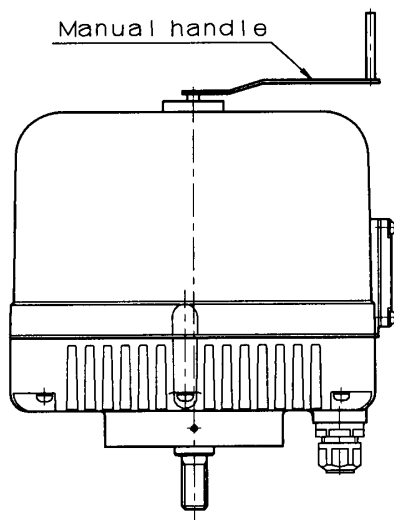

| | |
|-------------------|-------------|
| SIZE OF HEX. HOLE | OPPOSIT 5mm |
| 1 TURN OF HANDLE | 3mm-ACTION |
| LENGTH OF HANDLE | 100mm |

- FIG. 20-

1. Remove rubber cap on the body, and find a hexagonal handle hole thereunder.
 2. Insert manual handle into the hole to turn the shaft CW for upward, CCW for forward.
- Note : Do not apply excessively large force beyond the operation range, for it may cause troubles to the unit.

 CAUTION

When making manual operation,
 be sure that power is off.
 If power is on while manual operation,
 the handle will suddenly return!



Confirm that power is OFF before making manual operation

11-2 Power operation

1. Before making power operation, confirm by manual operation that valve position is exactly matching with actuator's top / bottom limit position.
Note : Confirm that the shaft moves smoothly without eccentricity etc.
2. Check that the wiring is properly made also confirm with external signals that valve is exactly positioned at top and bottom limits.
Note : Confirm that the motor stops exactly at top / bottom signal positions, also that the lamp lights by the function of bottom torque limiter.
3. Start operation after the above confirmation is over.

12. MAINTENANCE / INSPECTION

⊗ Lubrication

As the major parts of the products are lubricated with long life di-sulfate molybdenum grease (MoS₂) before shipment, re-lubrication is in principle not required.

⊗ Inspection

When re-starting operation after a long period of rest, make the following confirmation.

1. Cut power off, confirm by manual operation that valve moves smoothly without eccentricity.
2. Open body cover and check if there is no condensation inside the unit, also no problem on wiring.
Note : After checking, firmly screw up the cover to prevent water ingress.

13. TROUBLE SHOOTING

| TROUBLE AND PROBABLE CAUSE | SOLUTION |
|---|--|
| MOTOR DOES NOT START UP | |
| ☼ Power is off | Supply power |
| Signal is off or below 2mA | Check signal |
| Circuits or terminal are open | Renew cables or re-connect terminal |
| Supply voltage is improper or too low | Check terminal voltage with a tester |
| Trouble on thermal protector (Ambient temperature is too low or valve is constrained) | Lower ambient temperature or check Valve Movement by manual handle |
| Limit switch is faulty | Renew limit switch |
| Motor is defective or lead wire is broken | Renew actuator |
| Over capacity for motor advancer | Replace advancer (condenser) |
| Load is insufficient for torque limiter function (Check if lamp lights) | Change the setting rate for torque limiter |
| INPUT SIGNAL AND OPENING POSITION ARE NOT MATCHING EACH OTHER | |
| ☼ ZERO / SPAN adjustment is improper | Re-adjust ZERO / SPAN volumes |
| MOTOR IS CONSTRAINED AT UPPER LIMIT | |
| ☼ Upper position limit switch is set out of range | Re-adjust the switch |
| Setting rate for torque limiter is too large (Option extra) | Change the setting rate for torque limiter |
| Limit switch is faulty | Renew limit switch |
| MOTOR IS CONSTRAINED AT LOWER LIMIT | |
| ☼ Setting rate for bottom torque limiter is too large | Change the setting rate for torque limiter |
| Limit switch is faulty | Change limit switch |

* For other situation of troubles than the above, please refer to our Sales Dept.

[OPTIONAL EXTRAS]

- * Top / bottom torque limiters (for 3 way valve)
- * Top / bottom no voltage limit switches
- * Space heater

For any special version, contact our Sales Dept.